

2022 Interbranch Dance September 24--Tustin

1 NEW YEAR JIG J32 · 3/4L

Maureen Robson: RSCDS LI 8 · Crib: E-cribs · Diagram: Keith Rose's Diagrams

- 1-- 1c parallel Fig8 on sidelines, 1c Rsh to 2c to start
- 9-- Parallel Reels3 on sidelines, 1c Rsh to 2c to start, 1W facing out at end
- 17-- 1W followed by P cast round 2W | dance between 2c to M side ; cast round 2M to 2pl (2c up on [23-24]) (2,1,3)
- 25-- 1c+3c RHA ; 2c+1c LHA, 1W facing out at end.

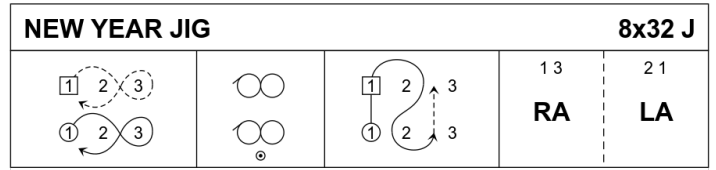

Maureen Robson, 1995, RSCDS Book 51

3C/4C longwise set.

2 THE RUBY RANT R32 · 3/4L

Francis Walduck: RSCDS XLIX 6 · Crib: E-cribs · Diagram: Keith Rose's Diagrams

- 1-- 1c+2c set | in square cast clw 2 places | cross RH (1c face out) (2,1,3)
- 9-- ½ Reels3 on sides, Rsh to 3c, at end 1c cross to 2pl ; 1c turn 1c, RH (3,1x,2)
- 17-- ½ Reels3 on sides, Lsh to 2c, at end 1c cross to 2pl ; 1c turn 4c, (pos) LH and finish BtoB facing opposite side for
- 25-- All Set as in DTr | All set, 1c pivoting R to face P ; 1c turn P RH ½ to (2,1,3)

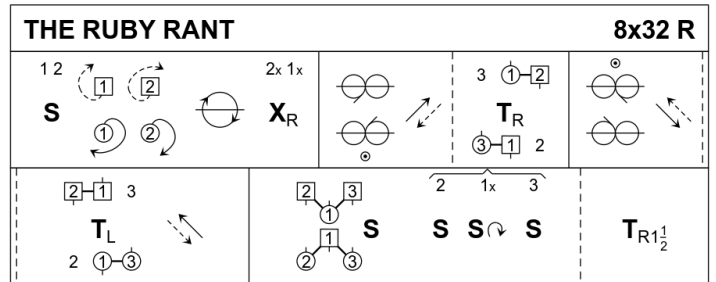

Francis Walduck, 2013, RSCDS Book 49.6

3C/4C longwise set.

3 MISS JANE MUIRHEAD OF DUNSMUIR S32 · 3/4L

Tom Winter: Dunsmuir Dances · Crib: E-cribs · Diagram: Keith Rose's Diagrams

- 1-- 1C long cast to 2pl (2c up) ; ½ Fig8 up (2,1x,3)
- 9-- All set | cross RH ; All set | 2c+3c cross RH while{2} 1c turn RH & pivot R to face 1c, RH
- 17-- 1c Turn 1c, BH | pass Rsh ; turn 2c, BH | pass Rsh to (2,1,3)
- 25-- Circle6 and back

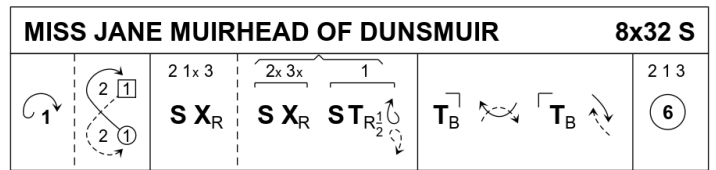

Thomas Winter, 2000, Dunsmuir Dances, www.rscds-sf.org

3C/4C longwise set.

4 THE BEES OF MAGGIEKNOCKATER J32 · 4/4L

John Drewry: Thirty Popular Dances, Volume Two · Crib: E-cribs · Diagram: Keith Rose's Diagrams

- 1-- 1c cross RH | cast off (2c up) ; 1c+3c RHA, finish as pairs 1M+3W & 3M+1W facing out on W/M side in promhold
- 9-- Pairs+ 2c+4c Rsh ½Reels3 on sides ; pairs meet & take P in promhold for Lsh ½Reels3 on sides
- 17-- Meet and repeat (as pairs Rsh ½Reels3 ; with P Lsh ½Reels3)
- 25-- 1c (passing inside) turn 3c ½ Easy Hand ; 1c cross and passing inside turn 4c EH ½ (to 2,3,4,1)

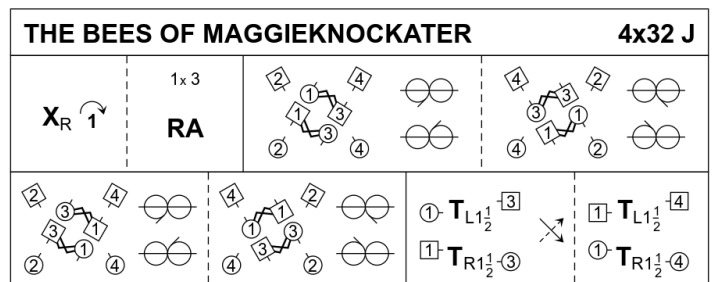

John Drewry, 1975, Canadian Book, RSCDS Thirty Popular Dances Vol 2

4C/4C longwise set.

5 A TRIBUTE TO PETER MCBRYDE S32 · 3/3L

Louis Emslie: T.A.C. 50th Anniversary Collection · Crib: MiniCrib · Diagram: Keith Rose's Diagrams

- 1-8 1s dance Inveran reels with 2s+3s
- 9-20 1+2s+3s dance 3 couple R&L
- 21-24 1+2s+3s set & 1s cast down 1 place as 2s dance up to top. 2 1 3
- 25-32 1s+3s dance the Espagnole to end 2 3 1:
25-26 1s+3s cross (Ladies lead across RH passing between Men) with Ladies changing places RH
27-28 1s+3s cross back (Men lead across RH between Ladies) with Men changing places RH
29-32 3s turn RH as 1s turn LH to places

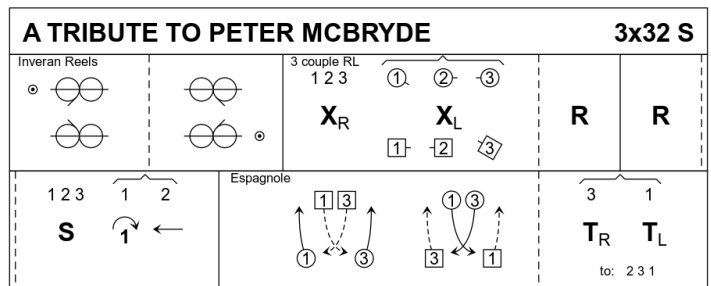

6 THE MONTGOMERIES' RANT R32 · 3/4L

Castle Menzies (18C): RSCDS X 1 · Crib: E-cribs · Diagram: Keith Rose's Diagrams

- 1- 1c cross RH | cast off (2c up) ; cross LH | cast L (W up, M down)
- 9- 2c+1W & 1M+3c Rsh Reels3 across
- 17- 1c NHJ set to 2W (swivel ½ inwards), set to 3M (veer L together), set to 3W (swivel ½ inwards), set to 2M (and face own 2cnr)
- 25- Reels3{6} on the sides, Rsh to 2cnr | 1c cross RH to 2pl

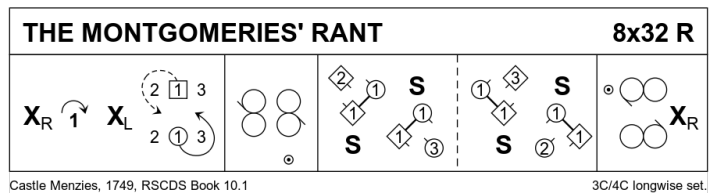

Break

7 ROARING JELLY J32 · 3/4L

Hugh Foss: Glendarroch Scottish Dance Sheets · Crib: E-cribs · Diagram: Keith Rose's Diagrams

- 1- 1c cross RH | cast off (2c up) ; cross RH, 1c casts R round 3cnr to finish in line across between 2cnr and 3cnr
- 9- Circle6 and back
- 17- 1c change places up/dn RH | Fig8 round 4cnr and 1cnr, start Rsh), finish on sideline facing 2cnr
- 25- 1c Reels3{6} on opposite sides (Rsh to 2cnr) | cross RH

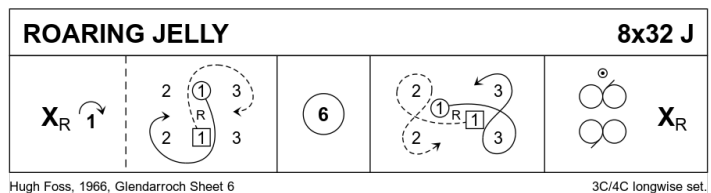

8 THE INIMITABLE DEREK R32 · 3/4L

Roy Goldring: Magazine Dances 2005-2009 · Crib: E-cribs · Diagram: Keith Rose's Diagrams

- 1- 1W+2W & 1M+2M turn 1¼ EH, 1c starting inwards, into line across with 1c BtB in the middle | 1c+2c set ; turn with the other hand ¾ (1c starts up) to (2,1,3), 2c facing out
- 9- Opposing Reels3 on the sides, 1c start to the R (1M Rsh to 3M, 1W Rsh to 2W), on [13-14] 1c cross to »2cnr position, on [15-16] 1c turn 2cnr persons (2W and 3M) RH into 2diagonal line
- 17- 1c+2cnrs BiL | 1c turn LH to join 1cnr with RH ; BiL | 1c turn LH to finish side by side in the centre, 1W facing up, 1M down
- 25- 1W+2W+3W & 1M+2M+3M RHA ; 1M+1W dance out the end and cast R into (2,1,3)

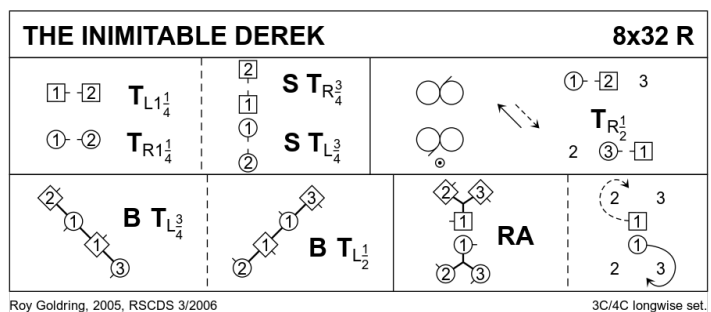

9 THE GLASGOW HIGHLANDERS S32 · 2/4L

RSCDS II 3 · Crib: E-cribs · Diagram: Keith Rose's Diagrams

2 chords. On 2nd chord 1W crosses down to R of P, 2W moves 1 place up and 2M crosses to her place, so 1c faces 2c across.

- 1-- 1c+2c R&L, finish with 2M between 2W & 1W facing down and NHJ, 1M behind him
- 9-- 1W+2M+2W dance down the middle, 1M following ; all turn (W inwards, M R about) 1M NHJ with the women, and 2M following, dance up to finish in line across, the W on the sidelines facing P in the middle (1c on M side)
- 17-- 1c+2c set to P: Glasgow Highlanders step (M may do some other Highland step)
- 25-- Reels4 {6} across the dance | 1c lead down the M side and 2c up the W side to face next couple. On reaching the top, 2c waits inactive on own side ; on reaching the bottom 1c waits inactive on own side.

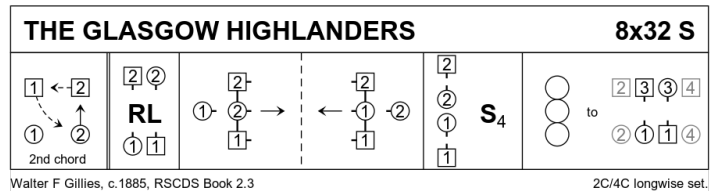

Notes: The RSCDS prescribes a 4c set, but the tradition is a longwise set 'for as many as will'.

10 JOHN CASS J32 · 5/5L

Peter Avery: RSCDS XLIX 10 · Crib: E-cribs · Diagram: Keith Rose's Diagrams

- 1-- 1c lead down (2c+3c up) ; lead up to 3pl and turn RH to face out on M side, 1W behind 1M
- 9-- 2M+3M & 1c & 4W+5W diag. Rsh Reel3, all pairs lead-change at both ends, finish 1W behind 1M giving Lsh to 4M
- 17-- 2W+3W & 1c & 4M+5M diag. Reel3, all pairs lead-change at both ends, 1c finish in 3pl facing down NHJ
- 25-- 1c dance between 4c, cast behind 5c (4c+5c up) ; 1c pivot turn with R elbow grip (2,3,4,5,1)

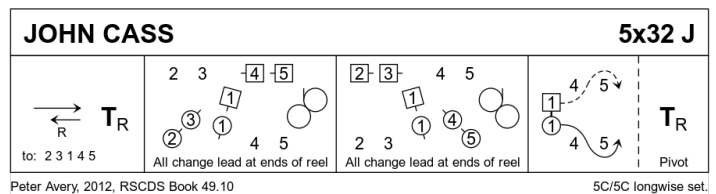

11 THE CUCKOO CLOCK R32 · 3/4L

Ian Barbour: Dance and Celebration · Crib: E-cribs · Diagram: Keith Rose's Diagrams

- 1-- 1c+2c+3c mirror Reels3 on the sides (2c start out and up)
- 9-- 1c+2c DblFig8 (1c start crossing down)
- 17-- 1c cross down to 3plx & cast up to 2plx while{4} 2c set+cross down to 3plx while{4} 3c cast up to 1pl and cross ; all turn RH (3x,1x,2x)
- 25-- 3c+1c+2c S&Link twice

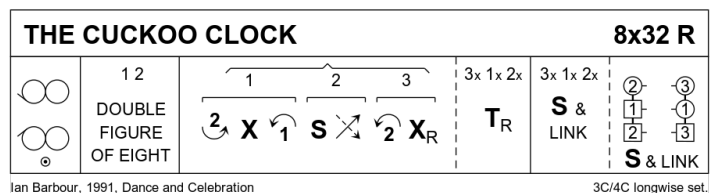

Break

12 THE LEGACY J32 · 3/4L

Iain Goddard: Pinewoods Collection Vol 2 · Crib: E-cribs · Diagram: Keith Rose's Diagrams

- 1-- All set | cross RH ; set | Turn RH 1/2 into promhold facing up
- 9-- All promenade (1,2,3)
- 17-- 1c cross RH | cast off (2Cup) ; 1/2 Fig8 up (2,1,3)
- 25-- 1c+3c R&L (2,1,3)

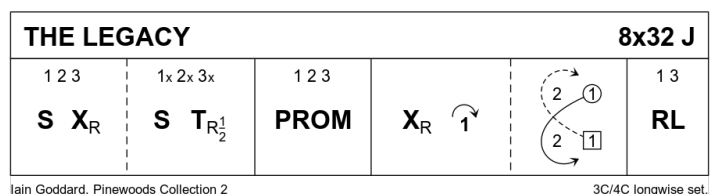

13 A SUMMER MEETING S32 · 3/3L

Irene Townshend: RSCDS XLVIII 9 · Crib: E-cribs · Diagram: Keith Rose's Diagrams

- 1-- 1c & 3c turn ¼ RH | set **while**{4} 2c ½ turn RH | cast away to opp side ; 1c+3c ½ Reel4 on centre line, 1M/3W end facing 2W/2M
- 9-- 2W+1M+3W+2M ½ Reel4 across, 3W & 1M end facing P on centre line ; 3c & 1c set to P | turn ¼ RH to sides (3,2,1)
- 17-- 3c+2c dance first 6 bars of Bourrel | petronella to sides (2,3,1)
- 25-- 3c+1c Poussette (2,3,1)

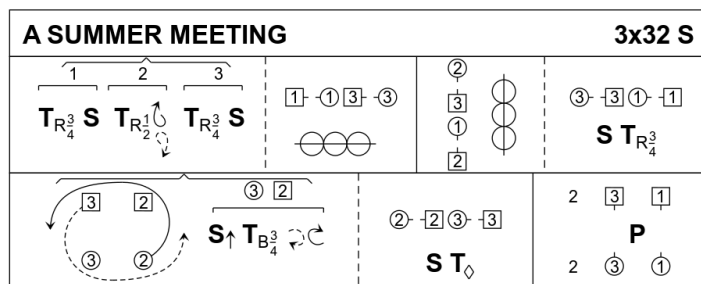

Irene Townshend, TAC 50th Anniversary Collection, RSCDS Book 48.9

3C/3C longwise set.

14 BOHEMIAN REFLECTIONS R32 · 3/4L

Holger Schuckelt: RSCDS LI 12 · Crib: E-cribs · Diagram: Keith Rose's Diagrams

- 1-- 1c lead down | cross and cast to 2plx (2c up) ; 1c turn LH 1 1/4 to midline, LSh to LSh, facing own sides
- 9-- 1c Teapots R, pass Rsh ; Teapots L (2,1x,3)
- 17-- 2c+1c La-Chain, 1M face out at end
- 25-- 1M followed by P casts round 3W | crosses to own side ; 1M casts round 3M **while** 1W dance up to 2pl, *pulling Rsh back* | all set

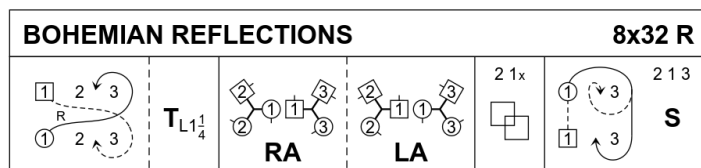

Holger Schuckelt, 2016, RSCDS Book 51

3C/4C longwise set.

15 THE AVIATOR J32 · 3/4L

Carola Fischer: RSCDS LII 9 · Crib: E-cribs · Diagram: Keith Rose's Diagrams

- 1-- 1c lead down (2c up), on [4] 1W crosses in front and, 1M following, casts up (round any standing M), to finish 1c in 2pl facing 3W
- 9-- 3W+1c+2M Rsh lead-change diag. Reel3 ; 1M dancing the full reel, **while for [13-16]** 1W turns 3M LH to finish behind 1M, both on midline facing up
- 17-- 2W+1c+3M Rsh lead-change diag. Reel3 ; 1W dancing the full reel, **while for [21-24]** 1M turns 3W LH to finish 1c in 2plx, 1W facing out
- 25-- 1c dance up (1W Rsh to 2M, 1M Rsh to 2W) | 1c dance Rsh round 2W to 2pl | All set.

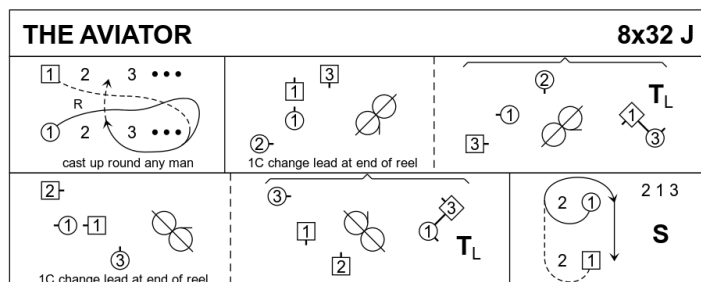

Carola Fischer, 2011, RSCDS Book 52.9, Tanzen & Tafeln im Kuckucksnest

3C/4C longwise set.

16 BALQUIDDER STRATHSPEY S32 · 3/4L

David Rutherford: RSCDS XXIV 2 · Crib: E-cribs · Diagram: Keith Rose's Diagrams

- 1-- 1c+2c+3c mirror Reels3 on the sides, 1c crossing down to begin
- 9-- Repeat, 1c crossing back to own sides
- 17-- 1c dance NHJ between 2c, face each other and set ; dance to top and cast off to face 1cnr (2c up)
- 25-- Turn CPCP (2,1,3)

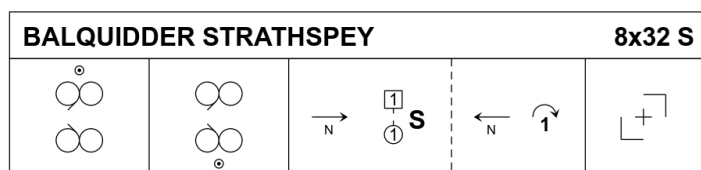

Rutherford, 1775, RSCDS Book 24.2

3C/4C longwise set.

17 TRIP TO TIMBER RIDGE R32 · 3/4L

Linda Henderson: RSCDS LII 12 · Crib: E-cribs · Diagram: Keith Rose's Diagrams

- 1-- 1c turn RH | cast (2c up) ; 1W+2c & 1M+3c RHA, 1c facing 1cnrs at end
- 9-- Corners Pass and Turn, on [16] 1c pull Rsh back to finish BtoB in centre facing opposite side
- 17-- DTr, on [23-24] 1c Petronella turn to 2pl (2,1,3)
- 25-- Circle6 and back

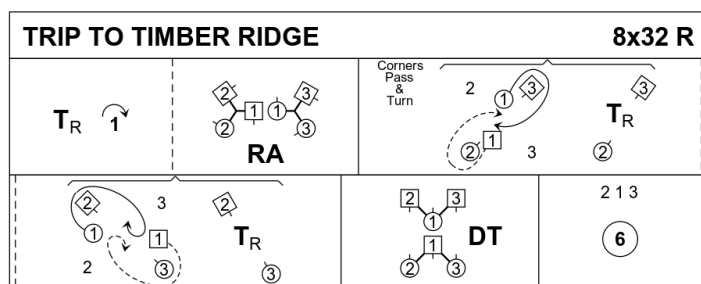

Linda Henderson, 2010, RSCDS Book 52.12

3C/4C longwise set.